

18 BIT RGB interface and optional touch panel



EA TFT040-77AITC
Dimension 90x90x3.8mm



EA TFT040-77AINN
Dimension 78x79x2mm

FEATURES

- 4.0" SQUARE TFT DISPLAY, IPS TECHNOLOGY
- 720X720 SQUARE SCREEN
- INTEGRATED CONTROLLER NV3052
- OPTIONALLY PCAP TOUCHPANEL OPTICALLY BONDED
- NO EXTRA ZIFF CONNECTOR NEEDED FOR TOUCHPANEL
- SUPER BRIGHT TYP 900 cd/m² (700 cd/m² INCL. PCAP)
- HIGH CONTRAST TFT PANEL
- 18 BIT RGB INTERFACE, 3 LINE SPI FOR INITIALISATION
- I²C INTERFACE FOR CAPACITIVE TOUCH PANEL (FT7511)
- WIDE TEMPERATURE RANGE (T_{OP} -20 .. +70°C)
- INDUSTRIAL GRADE DISPLAY

ORDERING CODES

- 4.0" TFT, 720X720 IPS COLOR DISPLAY
- AS ABOVE BUT WITH OPTICALLY BONDED PCAP

EA TFT040-77AINN
EA TFT040-77AITC

ACCESSORIES

- ZIFF CONNECTOR 40POS, 0.5 MM PITCH TOP CONTACT

EA WF050-40ST

REVISION

Date	Ref. Page	Revised No	Summary	Remark
2024-03-21		V0.9	First issue	Preliminary version

PRELIMINARY

CONTENTS

FEATURES	1
ORDERING CODES	1
Accessories	1
REVISION	2
Contents	3
General Description	4
Function Block Diagram	4
Dimension EA TFT040-77AINN	5
Dimension EA TFT040-77AITC	6
Interface signals	7
Pixel Format Image	8
Electrical Specifications	8
Electrical Absolute Maximum Ratings	8
Electrical Driving TFT LCD Panel	8
Backlight Specification	9
AC characteristic	9
EA TFT040-77AITC (Version with PCAP)	12
Interrupt signal from CTPM to Host	12
Optical Characteristic	13
Quality Assurance	15
Quality units	15
Inspection method	15
Quality Level	16
Definition	16
Recautions	22
Mounting Precautions	22
Operating Precautions	22
Electrostatic Discharge Control	22
Precautions For Strong Light Exposure	22
Storage	22
Handling Precautions For Protection Film	23
Initialisation example	24

GENERAL DESCRIPTION

EA TFT040-77AINN / -77AITC is a TFT-LCD module. It is composed of a TFT-LCD panel, driver IC, FPC, a backlight unit, optional capacitive sensor and cover. The 4.0" display area contains 720 x 3(RGB) x 720 pixels and can display up to 262K colors. This product accords with RoHS .

Parameter	Specifications	Unit
Screen size	4.0(Diagonal)	inch
Resolution	720 x 3(RGB) x 720	Pixel
Active area	71.928 x 71.928	mm
Outline dimension	90.1(W) x 90.1(H) x 3.845(D)(Exclude FPC)	mm
Display Mode	Normally Black/Transmissive	
Driving method	TFT active matrix	
Pixel pitch	0.0999(H)x0.0999(V)	mm
Input Signals	3 line SPI+18 bit RGB	
Surface treatment	-	
Color Depth	262K	Color
View Angle direction	Full	
Temperature Range	Operation	-20~70 °C
	Storage	-30~80 °C
Input voltage	3.3	V
RoHS Compliance	RoHS	

FUNCTION BLOCK DIAGRAM

The following diagram shows the function block of the 4.0inch color TFT-LCD module:

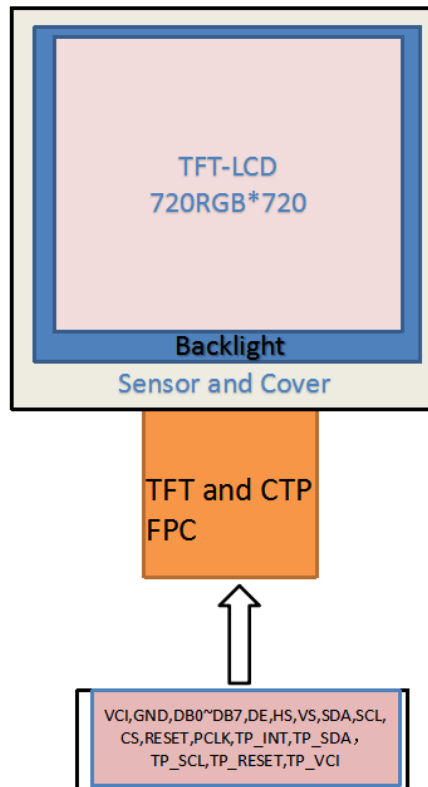

INTERFACE SIGNALS

TFT_FPC pin assignment:

Pin No	Symbol	Function	Remark
1	VLEDA	Power for LED backlight (Anode).	
2	VLEDK1	Power for LED backlight (Cathode).	
3	VLEDK1	Power for LED backlight (Cathode).	
4	GND	Ground.	
5	VCI	Power supply for analog and digital circuit.	
6	RESET	Global Reset Signal.Active Low.	
7	IM1(NC)	No connection.	
8	IM0(NC)	No connection.	
9	SDA	Serial interface DATA Input/Output.	
10	SCK	Serial interface Clock Input.	
11	CS	Chip select signal for SPI interface operation.	
12	PCLK	Dot clock signal for RGB interface operation.	
13	DE	Data enable pin for RGB interface operation.	
14	VSYNC	Vertical synchronizing input signal for RGB interface operation.	
15	HSYNC	Horizontal synchronizing input signal for RGB interface operation.	
16~33	DB0~DB17	18-bits data bus for RGB.	
34	GND	Ground.	
35	TP_INT	External interrupt to the host.	
36	TP_SDA	I ² C data input and output.	
37	TP_SCL	I ² C clock input.	
38	TP_RESET	The reset signal from host to CTPM, active low, and the low pulse width should be more than 1ms.	
39	TP_VCI	Power supply for CTP.	
40	GND	Ground.	

Datasheet for NV3052:

<https://www.lcd-module.de/fileadmin/eng/pdf/zubehoer/NV3052CGRB-Datasheet-V01.pdf>

PIXEL FORMAT IMAGE

Following figure shows the relationship between input signal and LCD pixel format.

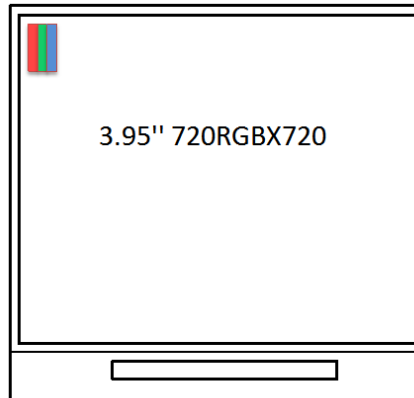

Figure 1 Pixel Format Image

ELECTRICAL SPECIFICATIONS

ELECTRICAL ABSOLUTE MAXIMUM RATINGS

The following are maximum values which, if exceeded may cause operation or damage to the unit.
(GND = 0V, Note 1)

Item	Symbol	Values		Unit	Remark
		Min.	Max.		
Power voltage for TFT-LCD	VCI	-0.3	4.5	V	
Power voltage for CTP	TP_VCI	2.7	3.6	V	
Operation Temperature	T _{OP}	-20	70	°C	
Storage Temperature	T _{ST}	-30	80	°C	

Note 1: The absolute maximum rating values of this product are not allowed to be exceeded at any times. Should a module be used with any of the absolute maximum ratings exceeded, the characteristics of the module may not be recovered, or in an extreme case, the module may be permanently destroyed.

ELECTRICAL DRIVING TFT LCD PANEL

(Unless otherwise specified, voltage Referenced to GND, T_A =25°C, Note 3)

Item	Symbol	Values			Unit	Remark
		Min.	Typ.	Max.		
Power for digital circuit (CTP)	TP_VCI	3.0	3.3	3.6	V	
Power for digital circuit	VCI	3.0	3.3	3.6	V	
Logic input voltage(VIH)	VIH	0.7*VCI	-	VCI	V	
Logic input voltage(VIL)	VIL	GND	-	0.3*VCI	V	
Logic output voltage(VOH)	VOH	0.8*VCI	-	VCI	V	
Logic output voltage(VOL)	VOL	GND	-	0.2VCI	V	

BACKLIGHT SPECIFICATION

Item	Sym.	Min	Typ.	Max	Unit	Note
Voltage for LED backlight	V_L	19.6	21.7	23.8	V	Note 1
Current for LED backlight	I_L	-	40	-	mA	Note 2
Luminous Uniformity	Avg	80	-	-	%	
Life Time	-	20000	-	-	Hr	Note 3

Note 1: The LED Supply Voltage is defined by the number of LED at $T_a=25^{\circ}C$ and $I_L=40mA$.

Note 2: Constant current.

Note 3: The “ life time” is defined as the module brightness decrease to 50% original brightness at $T_a=25^{\circ}C$ and $I_L=40mA$. The LED lifetime could be decreased if operating I_L is larger than 40mA.

AC CHARACTERISTIC

Reset timing characteristics

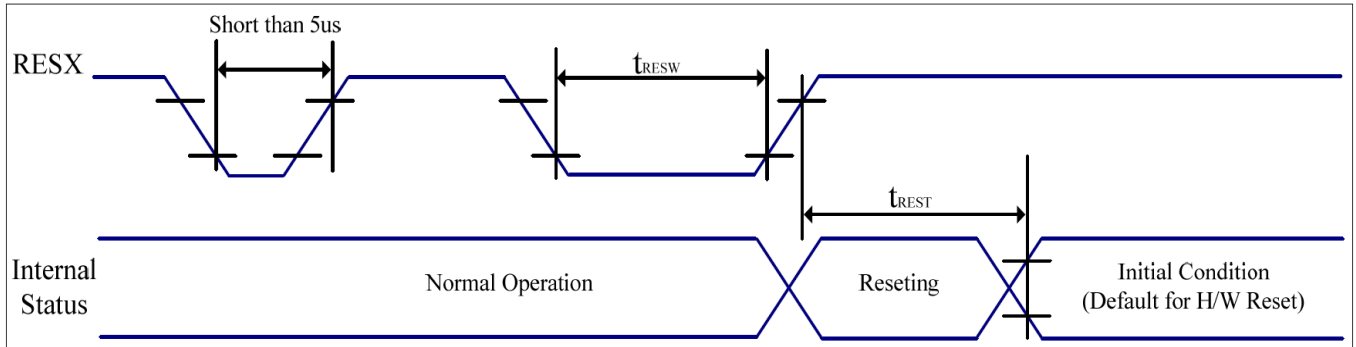

Figure 2 Reset timing characteristics

$V_{SS}=0V$, $IOVCC=1.65V$ to $3.6V$, $VCI=2.5V$ to $6.0V$, $T_a = -30^{\circ}C$ to $70^{\circ}C$

Symbol	Parameter	Related Pins	MIN	TYP	MAX	Note	Unit
t_{RESW}	*1) Reset low pulse width	RESX	10	-	-	-	us
t_{REST}	*2) Reset complete time	-	-	-	5	When reset applied during Sleep in mode	ms
		-	-	-	120	When reset applied during Sleep out mode	ms

Note1: Due to an electrostatic discharge on RESX line, spike does not cause irregular system reset according

To the table below.

RESX Pulse	Action
Shorter than 5us	Reset Rejected
Longer than 10us	Reset
Between 5us and 10us	Reset starts (It depends on voltage and temperature condition.)

Note 2: During the resetting period, the display will be blanked (The display is entering blanking sequence, which maximum time is 120ms, when Reset Starts in Sleep Out mode. The display remains the blank state in Sleep In mode) , then return to default condition for H/W reset.

Note 3: During Reset Complete Time, ID1/ID2/ID3 and VCOM value in OTP will be latched to internal register. After a rising edge of RESX, there is a H/W reset complete time (T_{rest}) which lasted 5ms..The loading operation will be done every time during this reset.

Note 4: Spike Rejection also applies during a valid reset pulse as shown below:

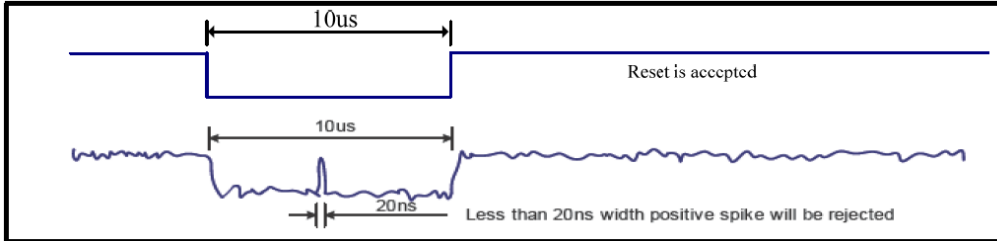

Note 5. It is necessary to wait 5msec after releasing RESX before sending commands. Also Sleep Out command cannot be sent for 120 msec.

Parallel 24/18/16-bit RGB Interface Timing Characteristics

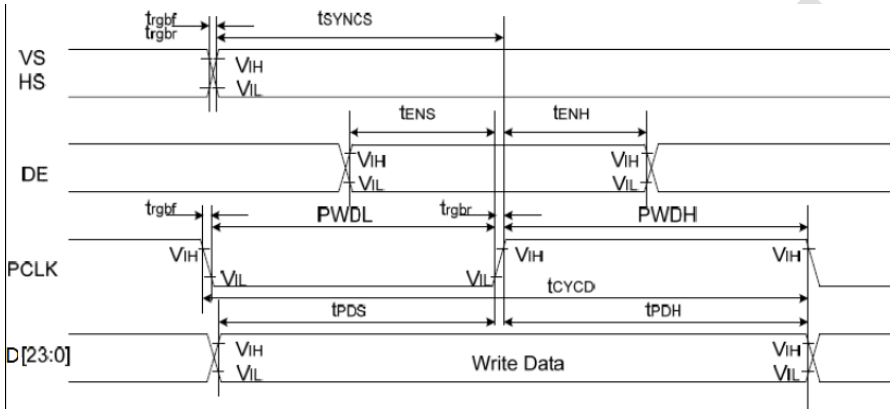

Figure 3 Parallel 24/18/16-bit RGB Interface Timing Characteristics

Signal	Symbol	Parameter	min	max	Unit	Description
VS/HS	tsyncs	VS/HS setup time	5	-	ns	24/18/16-bit bus RGB interface mode
	tsynch	VS/HS hold time	5	-	ns	
DE	tens	DE setup time	5	-	ns	
	tenh	DE hold time	5	-	ns	
D[23:0]	tpos	Data setup time	5	-	ns	
	tpdh	Data hold time	5	-	ns	
PCLK	pwdh	PCLK high-level period	13	-	ns	
	pwdl	PCLK low-level period	13	-	ns	
	tcyd	PCLK cycle time	28	-	ns	
	trgbf, trgbr	PCLK,HS,VS rise/fall time	-	15	ns	

Note 1: IOVCC=1.65 to 3.6V, VCI=2.5 to 6V, VSSA=VSS=0V, Ta=-30 to 70°C

Serial interface characteristics (SPI)

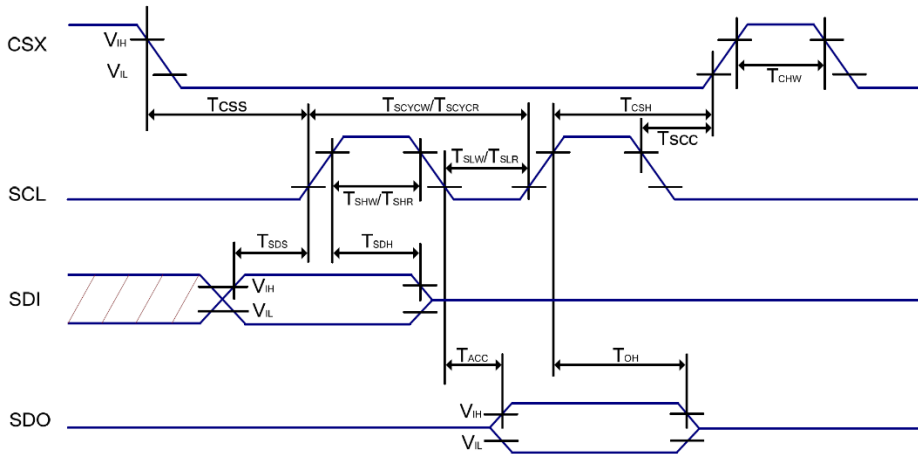

Figure 4 Serial interface characteristics

Table: SPI Interface Characteristics

Signal	Symbol	Parameter	MIN	MAX	Unit	Description
CSX	T _{CSS}	Chip select setup time	15	-	ns	-
	T _{CSH}	Chip select hold time	15	-	ns	
	T _{SCC}	Chip select setup time	20	-	ns	
	T _{CHW}	Chip "H" pulse width	40	-	ns	
SCL	T _{SCYCW}	Serial clock cycle (Write)	66	-	ns	-
	T _{SHW}	SCL "H" pulse width (Write)	10	-	ns	
	T _{SLW}	SCL "L" pulse width (Write)	10	-	ns	
	T _{SCYCR}	Serial clock cycle (Read)	150	-	ns	-
	T _{SHR}	SCL "H" pulse width (Read)	60	-	ns	
	T _{SLR}	SCL "L" pulse width (Read)	60	-	ns	
SDI	T _{SDS}	Data setup time	10	-	ns	-
	T _{SDH}	Data hold time	10	-	ns	
	T _{ACC}	Access time	10	50	ns	For maximum C _L =30pF For minimum C _L =8pF
	T _{OH}	Output disable time	15	50	ns	

Note 1: IOVCC=1.65 to 3.6V, VCI=2.5 to 6V, VSSA=VSS=0V, Ta=-30 to 70°C

Note 2: The rise time and fall time (tr, tf) of input signal is specified at 15 ns or less. Logic high and low levels are specified as 30% and 70% of IOVCC for Input signals.

EA TFT040-77AITC (VERSION WITH PCAP)

This module provides standard I2C interface for communication. The used Touchpanel panel IC is Focaltec FT 7511. Datasheet with application example can be found under:

https://www.lcd-module.de/fileadmin/eng/pdf/zubehoer/FT5426_5526Application%20Note%20Ver01.pdf

INTERRUPT SIGNAL FROM CTPM TO HOST

As for standard CTPM, host needs to use both interrupt signal and I2C interface to get the touch data. CTPM will output an interrupt request signal to the host when there is a valid touch. Then host can get the touch data via I2C interface. If there is no valid touch detected, the INT will output high level, and the host does not need to read the touch data. There are two kinds of method to use interrupt: interrupt trigger and interrupt polling

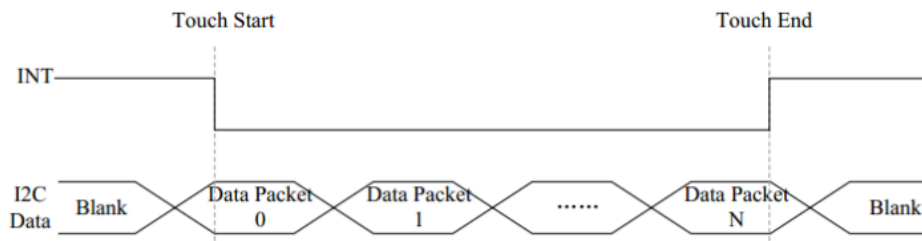

As for interrupt polling mode, INT will always be pulled to low level when there is a valid touch point, and be high level when a touch finished.

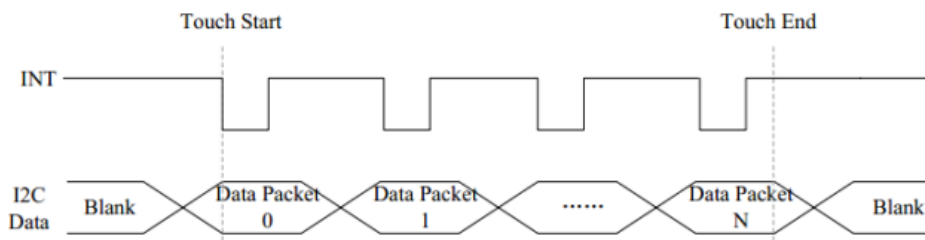

While for interrupt trigger mode, INT signal will be set to low if there is a touch detected. But whenever an update of valid touch data, CTPM will produce a valid pulse on INT port for INT signal, and host can read the touch data periodically according to the frequency of this pulse. In this mode, the pulse frequency is the touch data updating rate

OPTICAL CHARACTERISTIC

Optical characteristics are determined after the unit has been 'ON' and stable for approximately 30 minutes in a dark environment at 25 °C. The values specified are at an approximate distance 500mm from the LCD surface at a viewing angle of Φ and θ equal to 0°.

Item	Condition.	Values			Unit	Note	
		Min.	Typ.	Max.			
1) Contrast Ratio	Center	800	1000	-		Note(3)	
2) Response time	tr + tf	-	25	35	ms	Note (4)	
3) Viewing Angle (CR \geq 10)	θ_L	$\Phi=180^\circ$	80	85	-	Degree	Note(5)
	θ_R	$\Phi=0^\circ$	80	85	-		
	θ_T	$\Phi=90^\circ$	80	85	-		
	θ_B	$\Phi=270^\circ$	80	85	-		
4) Chromaticity	Wx	Typ-0.05	Typ+0.05	0.301	Note(2,6,7)		
	Wy			0.341			
	Rx			0.625			
	Ry			0.347			
	Gx			0.317			
	Gy			0.593			
	Bx			0.137			
	By			0.061			
5) LCD Luminance	Surface L	-	700	-	cd/m ²	Note(7)	

Note 1. Test Conditions: VCI=3.3V, I_L=40mA (Backlight current).
Ambient condition: 25°C \pm 2°C, 60 \pm 10%RH, under 2 Lux in the darkroom .

Note 2. Measure device: BM-5A (TOPCON), viewing cone=2°.

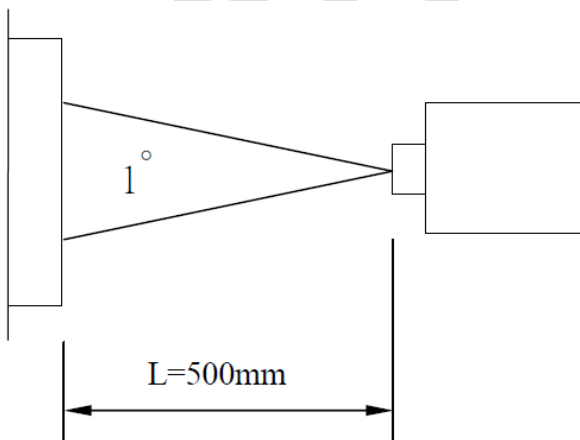

Note 3. Definition of Contrast Ratio:
CR = White Luminance (ON) / Black Luminance (OFF)

Note 4. Definition of response time: The response time is defined as the time interval between the 10% and 90% amplitudes.

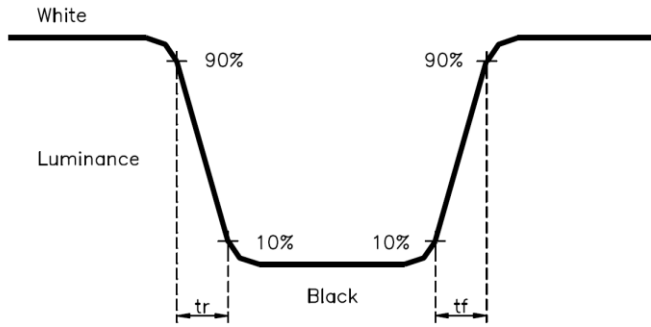

Note 5. Definition of view angle (θ , Φ):

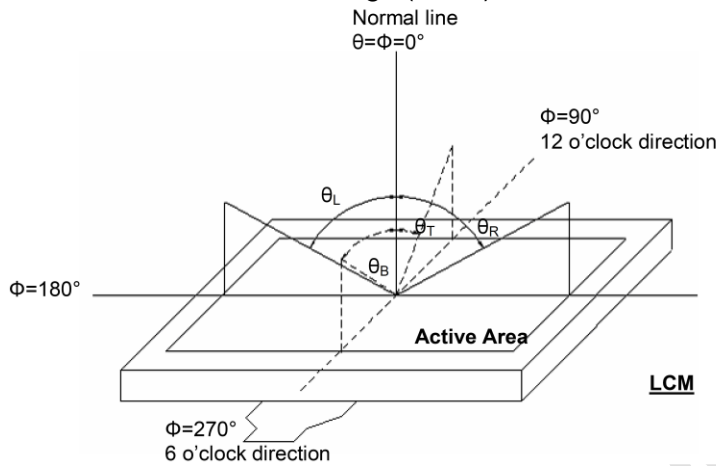

Note 6. Definition of color chromaticity (CIE1931), Color coordinates measured at center point of LCD.

Note 7. All input terminals LCD panel must be ground while measuring the center area of the panel. The LED driving condition is $I_L = 40\text{mA}$.

Note 8. Light source: C light.

QUALITY ASSURANCE

No.	Test Items	Test Condition	REMARK
1	High Temperature Storage Test	Ta=+80°C Dry 240h	
2	Low Temperature Storage Test	Ta=-30°C Dry 240h	
3	High Temperature Operation Test	Ta=70°C Dry 240h	
4	Low Temperature Operation Test	Ta=-20°C Dry 240h	
5	High Temperature and High Humidity Operation Test	Ta=60°C 90%RH 240h	
6	Electro Static Discharge Test	Panel surface / top case. Contact / Air : ±6KV / ±8KV, 150pF, 330Ω	Non-operating
7	Vibration Test (non-operating)	Frequency range: 10Hz ~ 500Hz Sweep:5g, Vibration: Sinusoidal Wave, 30min for X,Y,Z direction.	
8	Thermal Shock Test	-30°C(0.5h) ~ 80°C(0.5h) / 100 cycles	

* Ta= Ambient Temperature

Note:

1. The test samples have recovery time for 2 hours at room temperature before the function check. In the standard conditions, there is no display function NG issue occurred.
2. All the cosmetic specifications are judged before the reliability stress.

QUALITY UNITS

INSPECTION METHOD

An appearance inspection should be conducted at 30 cm or more distance/height from the inspector's eye sight to the LCD module surface under fluorescent light. The distance between LCD and fluorescent lamps should be 100 cm or more. Viewing angle for inspection is 45° from vertical against LCD.

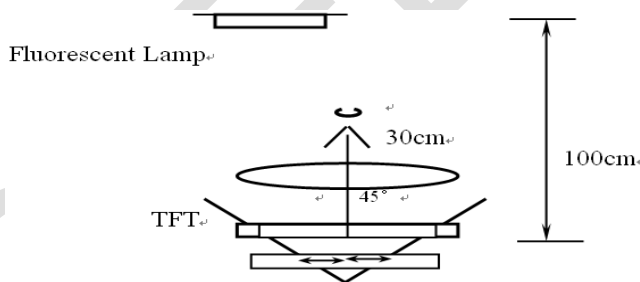

QUALITY LEVEL

The AQL for major and minor defects is defined as follows:

Partition	Definition	AQL
Major defect	Functional defective in product	0.25
Minor defect	Meet all functions of product but have some cosmetic defective	0.65

DEFINITION

The environmental condition of inspection

- 1) Ambient temperature : 22°C±5°C, 65±20%RH
- 2) Function inspection : less than 300Lux
- 3) Visual inspection : 750±150Lux

Definition of dot defect

The size of a defective dot full of a whole dot, and all bright dot or dark dot defect must be visible through ND 5% filter.

Bright dot

Dots appear bright and unchanged in size in which TFT is displaying.

single dot

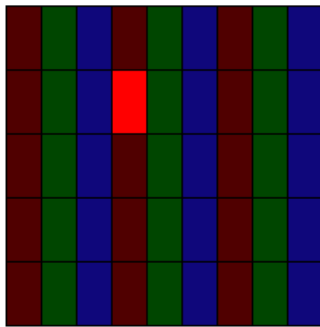

two adjacent dots

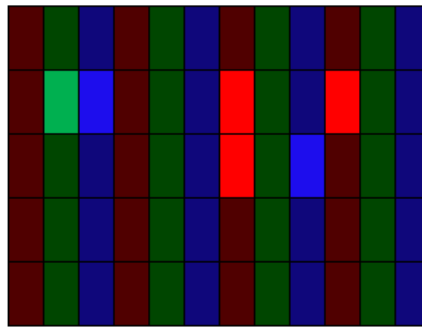

three adjacent dots

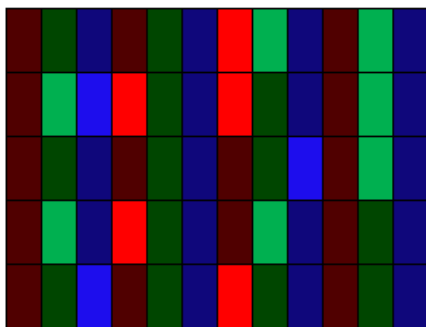

Dark dot

The same definition of bright dot, but always display dark

The usage of ND 5%

Use the ND 5% to cover bright dot within 2s, it should be judged OK if it's invisible.

Visual Inspection Standard

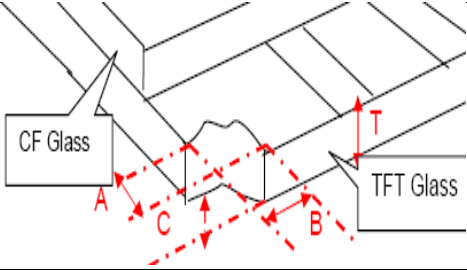
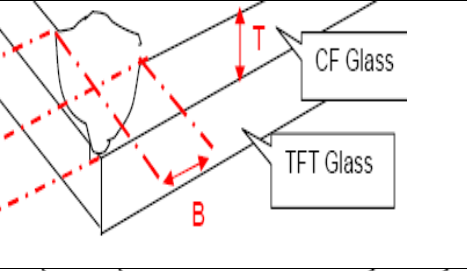
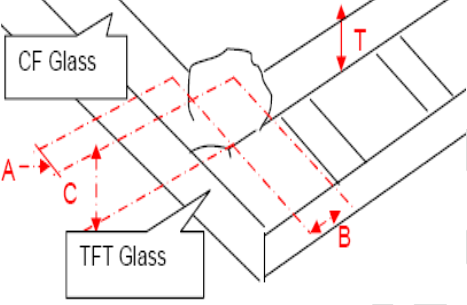
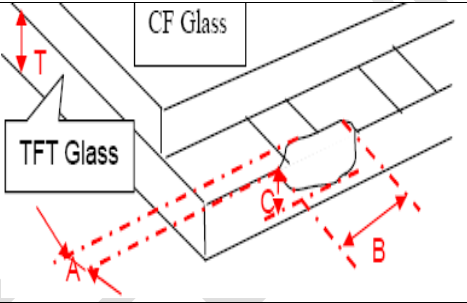
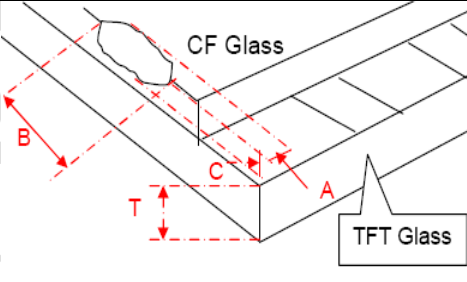
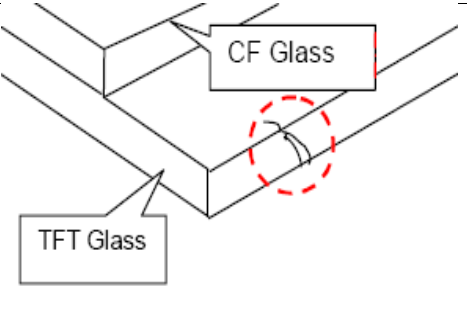
Defect	Inspection	Criteria
1 Corner Broken (Minor)	 <p>Diagram showing a corner broken defect on a CF Glass panel. Red dashed lines indicate dimensions A, B, C, and T. A callout box points to the CF Glass, and another points to the TFT Glass.</p>	<p>1. $A \leq 2.0$ mm , $B \leq 2.0$ mm , $C \leq T$ Ignore (No effect on function) 2. $A > 2.0$ mm , or $B > 2.0$ mm, Not allowed</p>
2 Corner Broken (Minor)	 <p>Diagram showing a corner broken defect on a CF Glass panel. Red dashed lines indicate dimensions A, B, C, and T. Callouts point to CF Glass and TFT Glass.</p>	<p>1. $A \leq 1.5$ mm , $B \leq 1.5$ mm , $C \leq T$ Ignore (No effect on function) 2. $A > 1.5$ mm , or $B > 1.5$ mm Not allowed 3. To be applied to both CF and TFT glass</p>
3 Corner Broken (Minor)	 <p>Diagram showing a corner broken defect on a CF Glass panel. Red dashed lines indicate dimensions A, B, C, and T. Callouts point to CF Glass and TFT Glass.</p>	<p>1. $A \leq 1.5$ mm , $B \leq 1.5$ mm , $C \leq T$ Ignore (No effect on function) 2. $A > 1.5$ mm , or $B > 1.5$ mm Not allowed 3. To be applied to both CF and TFT glass</p>
4 Pad Broken (Minor)	 <p>Diagram showing a pad broken defect on a TFT Glass panel. Red dashed lines indicate dimensions A, B, C, and T. Callouts point to CF Glass and TFT Glass.</p>	<p>1. $A \leq 0.8$ mm , $C \leq T$ Ignore B Length Ignore (No effect on function) 2. $A > 0.8$ mm, Not allowed</p>
5 Side Broken (Minor)	 <p>Diagram showing a side broken defect on a CF Glass panel. Red dashed lines indicate dimensions A, B, C, and T. Callouts point to CF Glass and TFT Glass.</p>	<p>1. $A \leq 0.8$ mm , $C \leq T$ Ignore B Length Ignore (No effect on function) 2. $A > 0.8$ mm, Not allowed</p>
6 Glass crack (Major)	 <p>Diagram showing a glass crack defect on a CF Glass panel. A red dashed circle highlights the crack. Callouts point to CF Glass and TFT Glass.</p>	<p>Not allowed</p>
7		

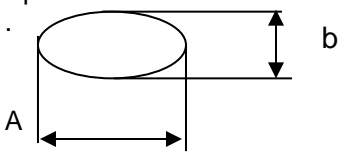
<p>Spot defect: (Minor)</p>	<p>Foreign/Black/White/Bright Spot/POL dent or bubble</p>  <p>$\Phi = a+l$</p>	<p>Note:</p> <table border="1" data-bbox="909 246 1492 459"> <thead> <tr> <th>Dimensions</th> <th>Acceptable Numbers</th> </tr> </thead> <tbody> <tr> <td>$\Phi \leq 0.1\text{mm}$</td> <td>Ignore</td> </tr> <tr> <td>$0.1\text{mm} < \Phi \leq 0.20\text{mm}$</td> <td>2</td> </tr> <tr> <td>$0.2\text{mm} < \Phi \leq 0.30\text{mm}$</td> <td>1</td> </tr> <tr> <td>$\Phi > 0.30\text{mm}$</td> <td>0</td> </tr> </tbody> </table> <p>*1: defect that beyond AA area Ignored</p>	Dimensions	Acceptable Numbers	$\Phi \leq 0.1\text{mm}$	Ignore	$0.1\text{mm} < \Phi \leq 0.20\text{mm}$	2	$0.2\text{mm} < \Phi \leq 0.30\text{mm}$	1	$\Phi > 0.30\text{mm}$	0								
Dimensions	Acceptable Numbers																			
$\Phi \leq 0.1\text{mm}$	Ignore																			
$0.1\text{mm} < \Phi \leq 0.20\text{mm}$	2																			
$0.2\text{mm} < \Phi \leq 0.30\text{mm}$	1																			
$\Phi > 0.30\text{mm}$	0																			
<p>8 Line defect (Minor)</p>	<p>Scratch ; Fiber</p>	<p>Scratch :</p> <table border="1" data-bbox="909 616 1492 884"> <thead> <tr> <th>Dimensions</th> <th>Acceptable Numbers</th> </tr> </thead> <tbody> <tr> <td>$W \leq 0.03\text{mm}$</td> <td>Ignore</td> </tr> <tr> <td>$L \leq 5\text{ mm}$ $0.03\text{mm} < W \leq 0.05\text{mm}$</td> <td>2</td> </tr> <tr> <td>$L \leq 5\text{ mm}$ $0.05\text{mm} < W \leq 0.1\text{mm}$</td> <td>1</td> </tr> <tr> <td>Beyond Above, Not Allowed</td> <td></td> </tr> </tbody> </table> <p>Fiber:</p> <table border="1" data-bbox="909 952 1492 1153"> <thead> <tr> <th>Size</th> <th>Acceptable Numbers</th> </tr> </thead> <tbody> <tr> <td>$W \leq 0.03\text{mm}$</td> <td>Ignore</td> </tr> <tr> <td>$L \leq 5\text{ mm}$ $0.03 < W \leq 0.05\text{mm}$</td> <td>2</td> </tr> <tr> <td>Beyond Above, Not Allowed</td> <td></td> </tr> </tbody> </table> <p>Note: *1: defect that beyond AA area Ignored</p>	Dimensions	Acceptable Numbers	$W \leq 0.03\text{mm}$	Ignore	$L \leq 5\text{ mm}$ $0.03\text{mm} < W \leq 0.05\text{mm}$	2	$L \leq 5\text{ mm}$ $0.05\text{mm} < W \leq 0.1\text{mm}$	1	Beyond Above, Not Allowed		Size	Acceptable Numbers	$W \leq 0.03\text{mm}$	Ignore	$L \leq 5\text{ mm}$ $0.03 < W \leq 0.05\text{mm}$	2	Beyond Above, Not Allowed	
Dimensions	Acceptable Numbers																			
$W \leq 0.03\text{mm}$	Ignore																			
$L \leq 5\text{ mm}$ $0.03\text{mm} < W \leq 0.05\text{mm}$	2																			
$L \leq 5\text{ mm}$ $0.05\text{mm} < W \leq 0.1\text{mm}$	1																			
Beyond Above, Not Allowed																				
Size	Acceptable Numbers																			
$W \leq 0.03\text{mm}$	Ignore																			
$L \leq 5\text{ mm}$ $0.03 < W \leq 0.05\text{mm}$	2																			
Beyond Above, Not Allowed																				
<p>9 (Minor)</p>	<p>Envelop silicon on glass</p>	<p>1. Silicon area not match with document request reject 2. Silicon not cover with all ITO reject 3. Glue wet to the LCD upper POL or the bottom POL. And the connector over the LCD PIN. (Include FFC、FPC...etc) reject</p>																		
<p>10 (Major)</p>	<p>TCP IC/ FPC</p>	<p>1. the line broken off reject 2. oxidation/broken/fold-injury in acute angle / distortion on golden fingers reject 3. FPC protection cover fix no good or deflection over the drawing request reject 4. Scratch/Surface Dirty or mark that doesn't affect display Ignored</p>																		
<p>11 (Minor)</p>	<p>Backlight</p>	<p>1. The size don't match with the drawing . reject 2. Surface Dirty or mark that can not wipe out Ignored 3. Scald reject 4. Uneven or scratch on surface that doesn't affect display Ignored</p>																		
<p>12 (Major)</p>	<p>Weld</p>	<p>1. tack weld reject 2. welding short out reject 3. very little or too much tin reject</p>																		

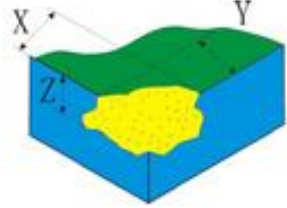
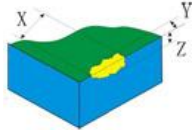
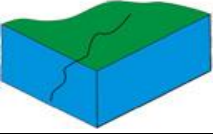
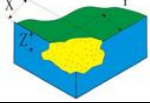
		4.FPC cock reject
13 (Minor)	LCD rainbow	1.area > 1/4 LCD display area reject 2.visible at display reject
14 (Minor)	protect film	Neglect any defect on protect film, such as: scratches/bubbles/particles
15 (Minor)	Chipping on Sensor(Corner) 	1.No damage on Mark & circuit : 2.X<2.0mm , Y<2.0mm ,Z≤ Thickness of Glass
	Chipping on Sensor(edge) 	1.No damage on Mark & circuit : 2.X<5.0mm , Y<2.0mm ,Z≤ Thickness of Glass
	Crack 	Rejected
16 (Minor)	Chipping on Conver 	Invisible from Front Surface
		X, Y≤0.25,Z≤1/2 Thickness of Glass
17 (Minor)	Pinhole	D≤0.25mm, N≤3; 0.25mm<D, Rejected, but can be fixed by oil paint.

Electronic Inspection Standard:

Defect	Inspection	Criteria	
1 Spot defect (Minor)	Foreign particle/Black/White spot/Bubble .etc.	Dimensions	Acceptable Numbers
		$\Phi \leq 0.1\text{mm}$	Ignore
		$0.1\text{mm} < \Phi \leq 0.20\text{mm}$	2
		$0.2\text{mm} < \Phi \leq 0.30\text{mm}$	1
		$\Phi > 0.30\text{mm}$	0
Note: *1: defect that beyond AA area Ignored			
2 Line defect (Minor)	Scatched ; Fiber	Scratch:	
		Dimensions	Acceptable Numbers
		$W \leq 0.03\text{mm}$	Ignore
		$L \leq 5\text{ mm}$ $0.03\text{mm} < W \leq 0.05\text{mm}$	2
		$L \geq 5\text{ mm}$ or $W \geq 0.05\text{ mm}$	0
		Fiber:	
		Size	Acceptable Numbers
		$W \leq 0.03\text{mm}$	Ignore ,
		$L \leq 5\text{mm}$ $0.03 < W \leq 0.05\text{mm}$	2
		Beyond Above, Not Allowed	
Note: *1: defect that beyond AA area Ignored			
3 (Minor)	Bright/dark dot By sub-pixel	Dimensions	Acceptable Numbers
		Single bright dot	$N \leq 1$
		Two adjacent bright dots	reject
		Three adjacent bright dots	reject
		Single dark dot	≤ 2
		Two adjacent dark dots	≤ 0
		Three adjacent dark dots	reject
1: Total dots ≤ 2			
4 (Minor)	Tiny Bright dot	Invisible by ND5% Filter, Ignore; If visible, $\Phi \leq 0.1\text{mm}$, Ignore ; $0.1\text{mm} < \Phi \leq 0.2\text{mm}$, $N \leq 2$; $0.2\text{mm} < \Phi \leq 0.30\text{mm}$, $N \leq 1$	
5 (Major)	Display	1. Missing segment, missing word reject 2. no display. reject 3. Viewing angle not right. reject 4. Display abnormal reject	
6 (Major)	Mura/ hot spot/ Light leak (apply to all patterns)	judge by ND5% filter or limit sample	

7 (Major)	flicker	judge by ND 5% filter in grey pattern or limit sample
8 (Major)	Electricity parameter (VoP/Current)	Over the production SPEC reject
9 (Major)	Backlight	1、 LED died off reject 2、 Display on uniformity Invisible by ND5% filter 3、 Brightness does not match the SPEC reject 4、 light leak Invisible by ND5% filter
10 (Major)	Cross talk	Limit sample
11 (Major)	Touch defect	Reject

RECAUTIONS

Please pay attention to the following when you use this TFT LCD module.

MOUNTING PRECAUTIONS

- (1) You must mount a module using arranged in four corners or four sides.
- (2) You should consider the mounting structure so that uneven force (ex. Twisted stress) is not applied to the module. And the case on which a module is mounted should have sufficient strength so that external force is not transmitted directly to the module.
- (3) Please attach a transparent protective plate to the surface in order to protect the polarizer. Transparent protective plate should have sufficient strength in order to the resist external force.
- (4) You should adopt radiation structure to satisfy the temperature specification.
- (5) Acetic acid type and chlorine type materials for the cover case are not describe because the former generates corrosive gas of attacking the polarizer at high temperature and the latter causes circuit break by electro-chemical reaction.
- (6) Do not touch, push or rub the exposed polarizers with glass, tweezers or anything harder than HB pencil lead. And please do not rub with dust clothes with chemical treatment. Do not touch the surface of polarizer for bare hand or greasy cloth. (Some cosmetics are determined to the polarizer)
- (7) When the surface becomes dusty, please wipe gently with adsorbent cotton or other soft materials like chamois soaks with petroleum benzene. Normal hexane is recommended for cleaning the adhesives used to attach front / rear polarizers. Do not use acetone, toluene and alcohol because they cause chemical damage to the polarizer.
- (8) Wipe off saliva or water drops as soon as possible. Their long time contact with polarizer causes deformations and color fading.
- (9) Do not open the case because inside circuits do not have sufficient strength.

OPERATING PRECAUTIONS

- (1) The spike noise causes the mis-operation of circuits. It should be lower than following voltage : $V=\pm 200\text{mV}$ (Over and under shoot voltage)
- (2) Response time depends on the temperature. (In lower temperature, it becomes longer.)
- (3) Brightness depends on the temperature. (In lower temperature, it becomes lower) And in lower temperature, response time (required time that brightness is stable after turned on) becomes longer.
- (4) Be careful for condensation at sudden temperature change. Condensation makes damage to polarizer or electrical contacted parts. And after fading condensation, smear or spot will occur.
- (5) When fixed patterns are displayed for a long time, remnant image is likely to occur.
- (6) Module has high frequency circuits. Sufficient suppression to the electromagnetic interference shall be done by system manufacturers. Grounding and shielding methods may be important to minimize the interference.

ELECTROSTATIC DISCHARGE CONTROL

Since a module is composed of electronic circuits, it is not strong to electrostatic discharge. Make certain that treatment persons are connected to ground through wristband etc. And don't touch interface pin directly.

PRECAUTIONS FOR STRONG LIGHT EXPOSURE

Strong light exposure causes degradation of polarizer and color filter.

STORAGE

When storing modules as spares for a long time, the following precautions are necessary.

- (1) Store them in a dark place. Do not expose the module to sunlight or fluorescent light. Keep the temperature between 5°C and 35°C at normal humidity.

(2) The polarizer surface should not come in contact with any other object. It is recommended that they be stored in the container in which they were shipped.

HANDLING PRECAUTIONS FOR PROTECTION FILM

(1) When the protection film is peeled off, static electricity is generated between the film and polarizer. This should be peeled off slowly and carefully by people who are electrically grounded and with well ion-blown equipment or in such a condition, etc.

(2) The protection film is attached to the polarizer with a small amount of glue. Is apt to remain on the polarizer. Please carefully peel off the protection film without rubbing it against the polarizer.

(3) When the module with protection film attached is stored for a long time, sometimes there remains a very small amount of glue still on the polarizer after the protection film is peeled off.

(4) You can remove the glue easily. When the glue remains on the polarizer surface or its vestige is recognized, please wipe them off with absorbent cotton waste or other soft material like chamois soaked with normal hexane.

INITIALISATION EXAMPLE

```

void init_TFT040_77AI(void)
{
...
...
...
}

void SPI_CommandWrite(void)
{
...
...
...
}

void SPI_DataWrite(void)
{
...
...
...
}

```

The source code can be downloaded from

https://www.lcd-module.de/fileadmin/html-seiten/deu/disk/development_service/TFT/TFT040_77AINN_init.c